

FIRE JACKETS

IKM dsc custom PFP jacket system has been developed to provide blast, jet fire (J) and hydrocarbon fire protection (H) to critical equipment. Accessibility is a major concern when considering a PFP system and ours allows easy access to the equipment for maintenance, inspections and operations.

PRODUCT SPECIALITIES INCLUDE:

- Fully prefabricated
- Jet/H fire rating certified by full scale testing
- Blast tested up to 1.4 bar
- Easy to remove/install for inspection (no tools or training needed)
- Minimum space required
- Customized Fit & Colors
- Lightweight & Weather Resistant
- On-Site Surveying Onshore & Offshore

Applications

- Valves
- Actuators
- Flanges
- Piping and Associated Equipment
- Process Vessels
- Wellheads
- Christmas Trees
- Riser Tensioners
- Cable Trays
- Storage tanks
- Flexible connections
- Structural support and hangers



Certifications





Full scale testing:



Typical integrated access panel:



3D modeling and CAD software to design and manufacture our jackets to help ensure a proper fit in the field

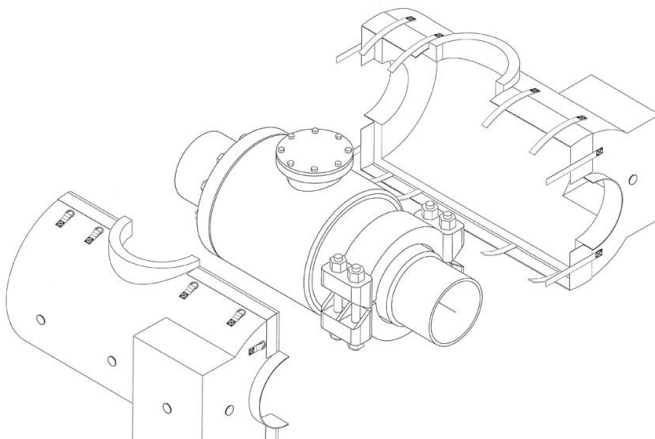

IKM dsc Engineering AS is a company within the IKM Group. We are a leading supplier of certified and prefabricated passive fire and blast wall systems, radiant shielding, fire jackets, wind walls/louvres/venting panels to the oil and gas industry. Having contributed to over 100 projects for various clients worldwide, our experience is extensive.